

SPECIFICATION FOR APPROVAL

承认书

Customer (客户) : _____

Product Name (产品名称) : Micro Dynamic Speaker

Zhen meiPart No. (盛群型号): MID08T16-001

Specification (臻美规格) : 16 Ω 3mW

Customer' s Model No. (客户型号): _____

Specification No. (规格书编号): MI-SQ-19123101

Number of the edition (版本号) : A0

CUSTOMER' S APPROVED SIGNATURE 客户承认盖章

CUSTOMER' S APPROVED SIGNATURE 客户承认盖章		



臻美智能电子
zhenmei smart electronics

广东臻美智能电子科技有限公司

Guangdong zhenmei intelligent electronic technology co., ltd.

地址:广东省东莞市塘厦镇华新智慧工业园华新路 22 号

TEL: 400-659-1989 FAX:0769-82196690

Http: www.zhenmeigd.com

E-MAIL: sales888@zhenmeigd.com

Approved by 核准	Checked by 审核	Issued by 制成

SPECIFICATION FOR APPROVAL**承认书**PAGE NO.
页码**4/8**PART . NO.
产品型号

MID08T16-001

C、适用范围 SCOPE

This specification applies speaker, MID08T16-016

此规格书适用于喇叭, MID08T16-016

D、GENERAL SPECIFICATIONS 一般规格

NO.	Item	Symbol	Unit	Specification	Condition
1	Dimension 尺寸		mm	$\phi 08 \times 5.0H$	
2	Rate/Max Power Rating 额定/最大功率		mW	Rate 3/Max 5	Max. Power:IEC-60268-5 Filter 60s On/120s Off 10 Cycles(Room TEMP.)
3	Impedance 阻抗	Ω	Ohm	$16 \pm 15\%$	
4	Resonance Frequency 谐振频率	Fo	Hz		At 1.0V
5	Output S.PL 输出音压	S.PL	dB	$96 \pm 3dB$	0.1W/0.1M at1.0K,1.2K,1.5K,2.0KHz average
6	Frequency Rang 有效频宽		Hz	Fo—20K	Output S.PL -10dB 输出音压-10dB
7	Max Distortion 最大失真		%	10%	At 1.0KHz 0.1V
8	Magnet Material 磁铁材质		mm	Nd-Fe-B	
9	Storage temp 贮存温度		$^{\circ}C$	-20~+50 $^{\circ}C$	
10	Operate temp 工作温度		$^{\circ}C$	-20~+55 $^{\circ}C$	
11	Buzze&Rattle 异常音				Not be audible at 0.23V sine wave between50Hz~3.0KHz 输入 0.23V 正弦波 50Hz 到 3.0KHz 之间无异常音
12	Protection Regulation 环保法规			RoHS	

SPECIFICATION FOR APPROVAL

承认书

PAGE NO.

页码

5/8

PART . NO.

产品型号

MID08T16-001

E、TYPICAL FREQUENCY RESPONSE CURVE 频率响应曲线

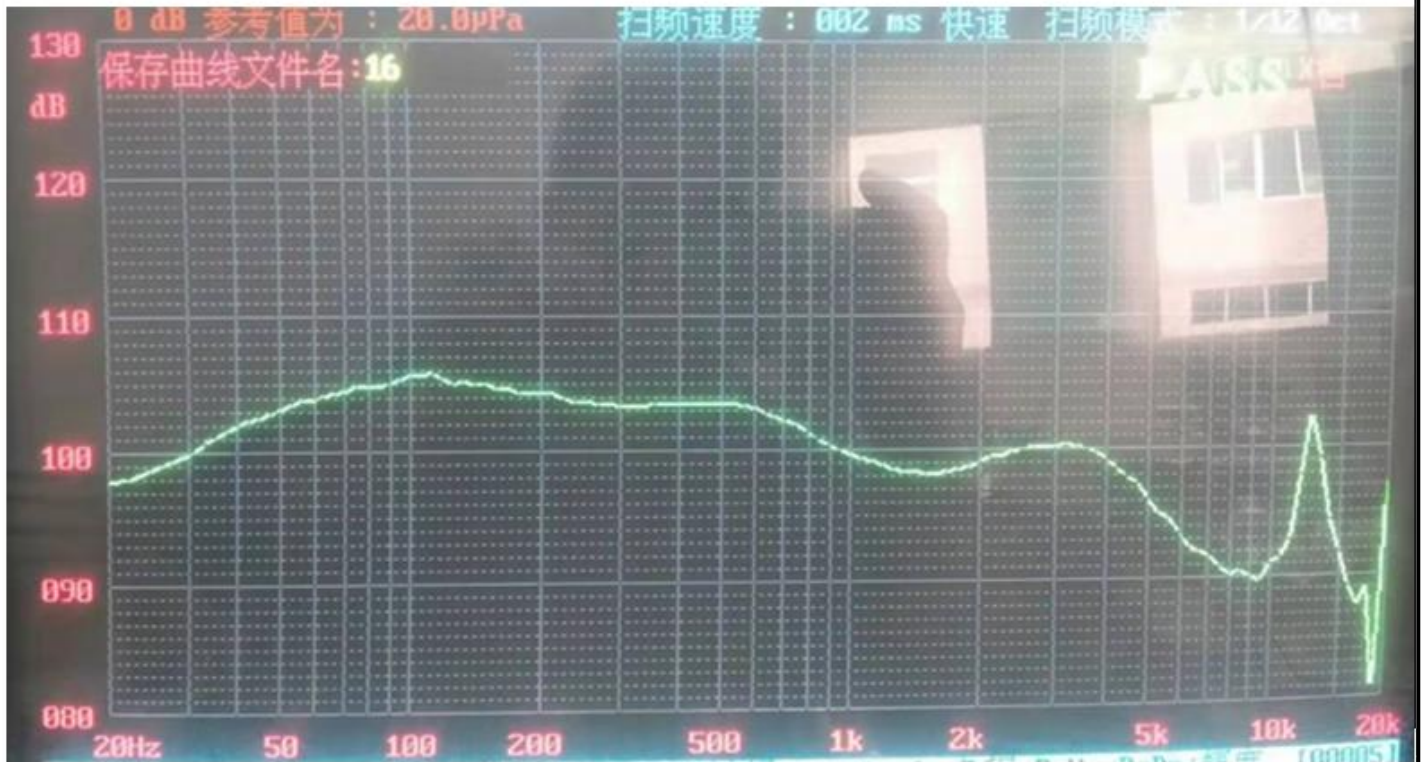

F、MEASUREMENT CIRCUIT 测量线路

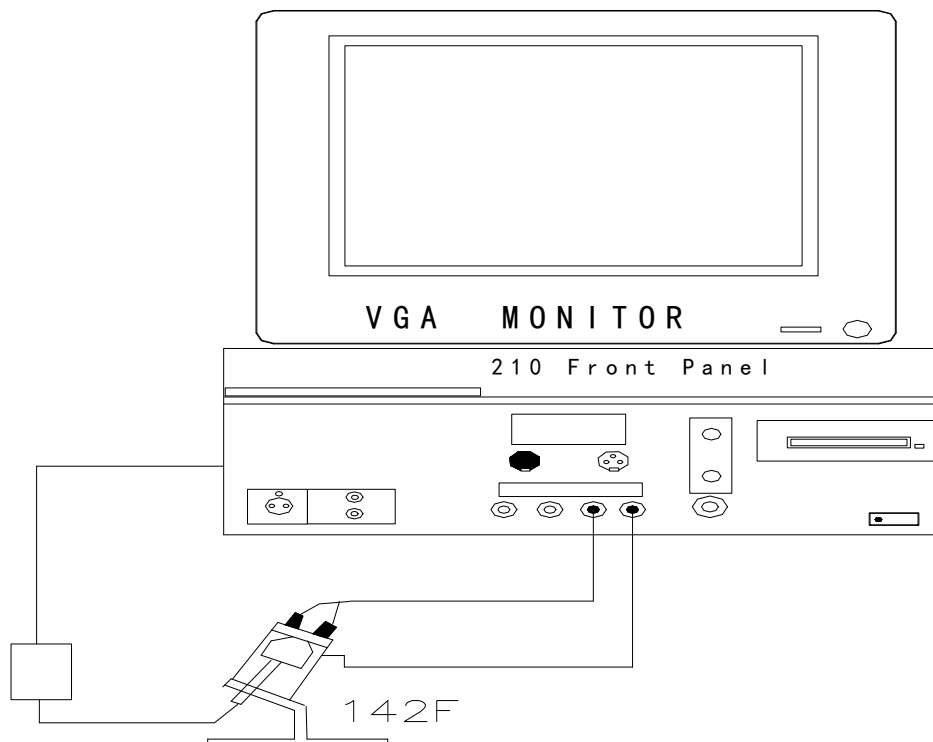

SPECIFICATION FOR APPROVAL

承认书

PAGE NO.

页码

6/8

PART . NO.

产品型号

MID08T16-001

G、MECHANICAL CHARACTERISTICS 机械特性

NO	Item	Test condition	Evaluation standard
1	Vibration Test 振动测试	Speaker shall be measured after being applied vibration of amplitude of 1.5mm with 10 to 55Hz band of vibration frequency to each of 3 per-pendicular directions for 2 hours. 振动周波数 10~55Hz, 全振幅 1.5mm 于 X, Y, Z 3 个方向各 2 个小时	No obstacle to be harmful to normal operation ; Damages,cracks,rusts and distortions. Should not be audible at 0.23V sinewave between50Hz~3.0KHz
2	Drop Test 跌落测试	Drop the speakers contained in normal box onto the board 40mm thick 10 times from the height of 75cm 将扬声器置于盒中, 自 75 公分高度落在 40mm 的木板上共 10 次	测试后无任何障碍妨碍正常操作, 且在输入 0.23V 正弦波从 50Hz 到 3.0KHz 之间无异常音。
3	Solderability 焊锡附着性 (connector excepted) 端子类不适合用此项	Stripped wire of lead wire are immersed in rosin For 5 seconds and then immersed in solder bath Of 270±5°C for 3±0.5 seconds. 裸线部分浸入松香溶液 5 秒后, 再浸入 270±5°C 熔融焊锡槽 3±0.5 秒,	90% min. stripped wires shall Be wet with solder.(Except the edge of terminal). 浸入裸线部分附着焊锡 90% 以上。(末端断面不算)
4	Lead Wire Pull Strength 线材拉力	The pull force shall be applied to double lead wire: Horizontal: 3. 0N(0. 306KG) for 30 seconds; Vertical: 2. 83N(0. 204KG) for 30 seconds. 双线材水平方向施以 3. 0N(0. 306KG) 的力量; 垂直方向施以 2. 83N(0. 204KG) 的力量, 各 30 秒	No damage and cutting off 线材不松动, 不脱落

SPECIFICATION FOR APPROVAL

承认书

PAGE NO.

页码

7/8

PART . NO.

产品型号

MID08T16-001

H、RELIABILITY TEST 信赖性试验

NO	Item	Test conditions	Evaluation standard
1	Load test 连续负荷	3mW white noise is applied for 98 hours,at room temp. 在室温下，输入功率 3mW，白杂音连续操作 98 小时	Being placed for 1 hours at +25 °C ,speaker shall be measured,No obstacle to be harmful to normal operation;damages,cracks,rusts,etc.should not be audible at 0.23V sine wave between50Hz~3.0KHz.Fo should meet intial one.S.P.L.deviation of unit should be within±3dB 经测试后，静置于+25℃环境中 1 小时后，测试无任何障碍妨碍正常操作，且在输入 0. 23V 正弦波从 50Hz 到 3. 0KHz 之间无异常音，Fo 与原规格值相同，输出音压变化量在±3dB

I、ENVIRONMENTAL TEST 环境试验

No.	Item	Test conditions
1	High temp. test 高温测试	After being placed in a chamber at +70°C for 72 hours. 置于+70℃环境中 72 小时
2	Low temp. test 低温测试	After being placed in a chamber at - 40°C for 72 hours. 置于-40℃环境中 72 小时
3	Humidity test 相对湿度测试	After being placed in a chamber at +60°C and 80±5% relative humidity for 72 hours.置于+60℃，相对湿度 80±5%环境中 72 小时
4	Temp. cycle test 温度循环测试	Low temperature -20 °C ±2°C (2 hour)/ high temperature +55 ±2°C (2 hour) : 1 cycle , total 10 cycles. Being placed for 6 hours at +25°C,receiver shall be measured. No obstacle to be harmful to normal operation ;damages, cracks, rusts and distortions, should not be audible at 0.23Vsine wave between50Hz~3.0KHz. S. P. L. deviation of unit should be within ±3dB. 低温 (-20±2℃) 2 小时/高温 (55±2℃) 2 小时，1 次循环，10 个周期； 经测试后，静置于+25℃环境中 6 小时后，测试后无任何障碍妨碍正常操作，在输入 0. 23V 正弦波从 50Hz 到 3. 0KHz 之间无异常音，Fo 与原规格值相同，输出音压变化量在+3dB 内。

J、APPEARANCE DRAWING 外观尺寸图

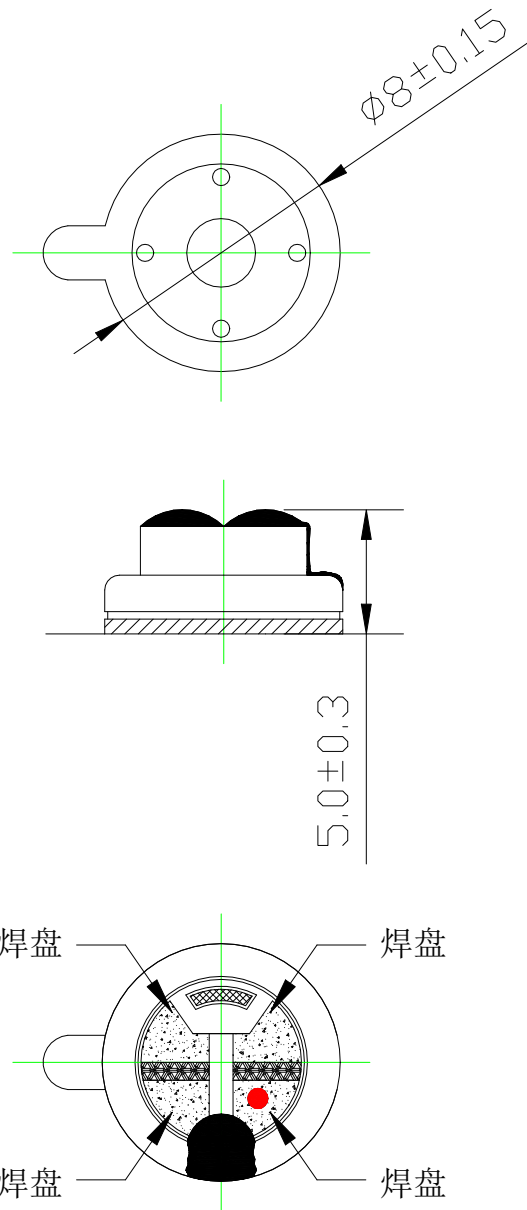

Unit: mm