

SPECIFICATION FOR APPROVAL

承认书

Customer (客户) : _____

Product Name (产品名称) : 微型扬声器(多媒体)

Zhenmei Part No. (臻美型号): MID2899-004-02

Specification (臻美规格) : 4 Ω 2W

Customer' s Model No. (客户型号): _____

Specification No. (规格书编号): XYD2804TR0828-03

Number of the edition (版本号) : A0

CUSTOMER' S APPROVED SIGNATURE 客户承认盖章		



广东臻美智能电子科技有限公司

Guangdong zhenmei intelligent electronic technology co., ltd.

地址:广东省东莞市塘厦镇华新智慧工业园华新路 22 号

TEL: 400-659-1989 FAX:0769-82196690

Http: www.zhenmeigd.com

E-MAIL: sales888@zhenmeigd.com

Approved by 核准	Checked by 审核	Issued by 制成
		JCF

SPECIFICATION FOR APPROVAL
承认书

PAGE NO.
页码

3/9

PART . NO.
产品型号

MID2899-004-02

產品概要/PRODUCT OUTLINE	
1	1-1 適用範圍/SCOPE This specification is applied to mobile telephone
	1-2 尺寸/DIMENSIONS As shown in fig (1)
	1-3 大小/SIZE Φ28±0.2 *10.0mm.
2	<p>標準試驗狀態 Standard Test Condition</p> <p>一般規格試驗狀態（特殊要求除外） 常溫 5～35℃，常濕 45%～85%，氣壓 860～1060hPa 但判定上有疑問時，試驗狀態為： 溫度 20±2℃，相對濕度 60%～70%，氣壓 860～1060hPa</p>
	<p>The test conditions unless otherwise specified should be</p> <p>Normal temperature 5 to 35℃, Normal humidity 45 to 85%</p> <p>And normal atmospheric pressure 860 to 1060hPa</p> <p>However, if there arises a doubt in judgement, the test conditions shall be as follows:</p> <p>Temperature 20±2℃</p> <p>Humidity 60%～70%</p> <p>Atmosphere 860～1060hPa</p>

SPECIFICATION FOR APPROVAL
承认书

PAGE NO.
页码

4/9

PART . NO.
产品型号

MID2899-004-02

電氣規格/ELECTRICAL SPECIFICATIONS

3-1 輸出音壓位准
SOUND PRESSURE LEVEL 90±3dB (at 1.0K,1.2K,1.5K,2.0KHz 0dB=20 μ Pa)
Measurement is as shown in fig(2), Input: 0.63V=0.1W

3-2 阻抗
IMPEDANCE ACZ: 4.0±15% ohm(at 2.0KHz,0.63V)

3-3 頻寬回應
FREQUENCY RESPONSE As shown in fig(3)

3-4 額定輸入功率
Rate Input Power 2W

3-5 最大輸入功率
Max Input Power 2.5W

3-6 異常音測試
Buzzes & Rattles Must be free audible noise
(From FO Hz to 20KHz frequency range,Input:3.0V)

3-7 最低共振頻率
LOWEST RESONANCE
FREQUENCY Fo:500Hz±20%

3-8 有效頻寬
FREQUENCY RANGE F0~20KHz

3-9 工作溫度
OPERATING
TEMPERATURE -20°C to +60°C

3-10 貯存溫度
STORE TEMPERATURE -40°C to +80°C

3

SPECIFICATION FOR APPROVAL
承认书

PAGE NO.
页码

5/9

PART . NO.
产品型号

MID2899-004-02

信賴性試驗/RELIABLE TEST

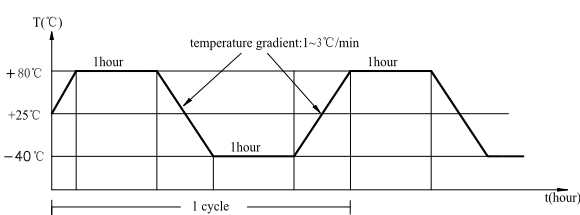
4-1 概述 GENERAL	After any following tests the response at 1 KHz shall not deviate more than ± 3 dB from the initial value
4-2 負載試驗 LOAD TEST	輸入電壓 / Input Power : 2.83V@2W 輸入信號 / Input Signal : white noise 時 間 / Duration : 96 hours 試驗後放置時間 / Duration of Recovery : 2hrs of conditions at 20°C
4-3 濕度試驗 HUMIDITY TEST	溫 度 / Temperature : $+40^{\circ}\text{C} \pm 3^{\circ}\text{C}$ 相對濕度 / Relative Humidity : 90%~95% 時 間 / Duration : 96 hours 試驗後放置時間 / Duration of Recovery : 4hrs of conditions at 20°C
4-4 低溫試驗 LOW TEMPERATURE TEST	溫 度 / Temperature : $-40^{\circ}\text{C} \pm 3^{\circ}\text{C}$ 時 間 / Duration : 96 hours 試驗後放置時間 / Duration of Recovery : 4hrs of conditions at 20°C
4-5 高溫試驗 HIGH TEMPERATURE TEST	溫 度 / Temperature : $+80^{\circ}\text{C} \pm 3^{\circ}\text{C}$ 時 間 / Duration : 96 hours 試驗後放置時間 / Duration of Recovery : 4hrs of conditions at 20°C
4-6 溫度迴圈試驗 TEMPERATURE CYCLES TEST	TEMPERATURE:  迴圈次數 / Cycles : 10 Cycles 試驗後放置時間 / Duration of Recovery : 4hrs of conditions at 20°C
4-7 落地試驗 TEST DROP TEST	落下方向 / Direction : 1 corner, 3 sides, 6 faces 落下回數 / Times : Once in each directions 高 度 / Height : From 1.5m (on the concrete) 試驗後放置時間 / Duration of Recovery : 4hrs of conditions at 20°C 依包裝實體一角三棱六面作自由落體試驗後, 實體外觀需正常
4-8 振動試驗 VIBRATION TEST	振 動 / Vibration : 10-55Hz 振 幅 / Amplitude : 1.5mm 時 間 / Times : 1 hour in each of 3axes 試驗後放置時間 / Duration of Recovery : 4hrs of conditions at 20°C

SPECIFICATION FOR APPROVAL
承认书

PAGE NO.
页码

6/9

PART . NO.
产品型号

MID2899-004-02

DIMENSIONS (fig.1)

外觀圖

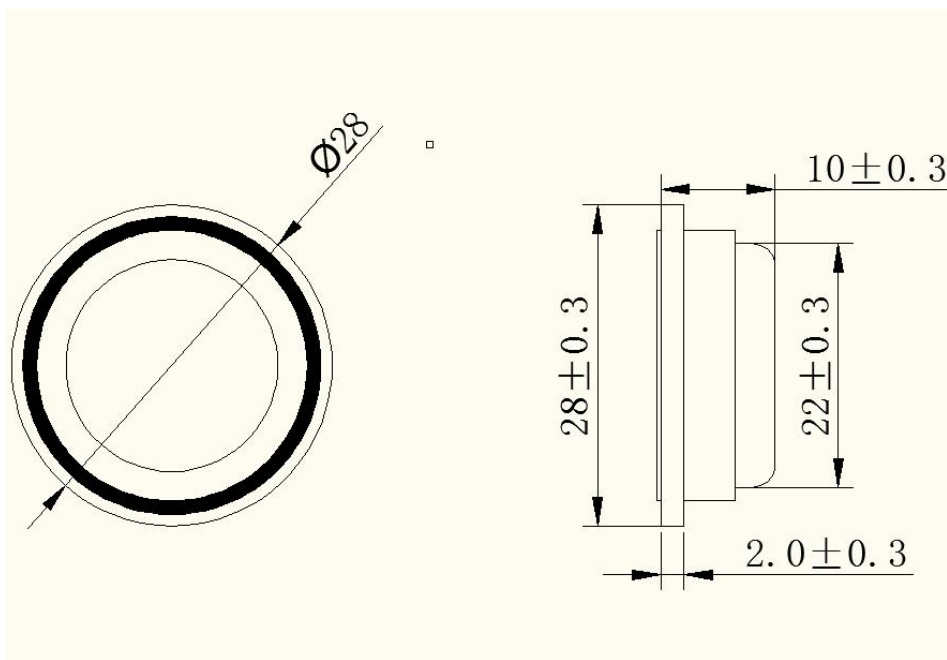

5

9	垫圈 GASKET	0.3T	1	
8	焊片 SPRING TERMINAL	SUS	2	
7	前盖 FRONT CAP	PPA or PBT	1	
6	音圈 VOICE COIL	COPPER WIRE	1	
5	膜片 DIAPHRAGM	PEEK or PEN	1	
4	U 铁 U YOKE	SPCE	1	
3	极片 POLE PIECE	SPCC	1	
2	磁钢 MAGNET	NdFeB	1	
1	主架 FRAME	PPA or PBT	1	
编号 No.	零件名称 PART NAME	材料 MATERIAL	数量 Q'TY	备注 REMARK

SPECIFICATION FOR APPROVAL
承认书

PAGE NO.
页码

7/9

PART . NO.
产品型号

MID2899-004-02

ELECTRICAL AND ACOUSTICAL MEASURING CONDITION (fig.2)

1. MEASUREMENT

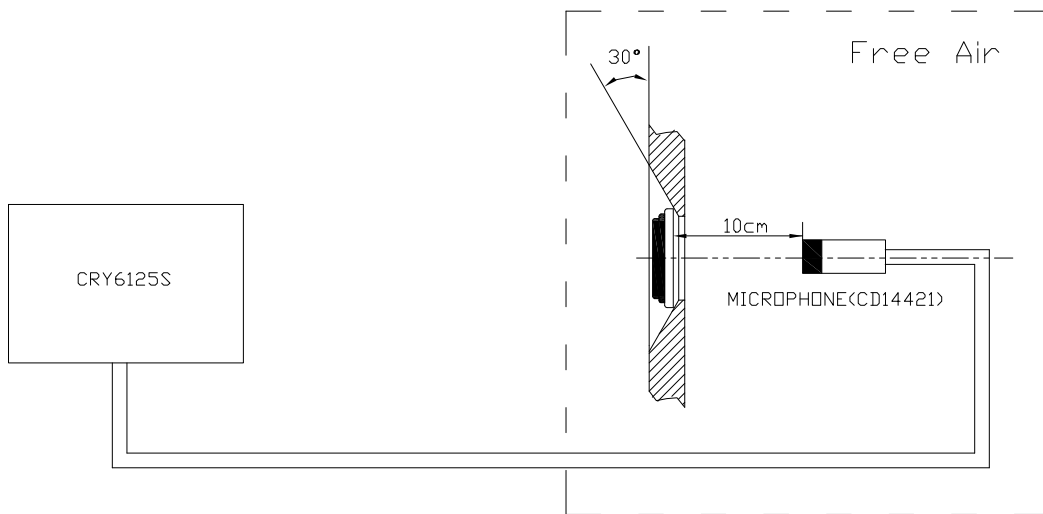

6

2.Measurement Board(IEC-268-5)

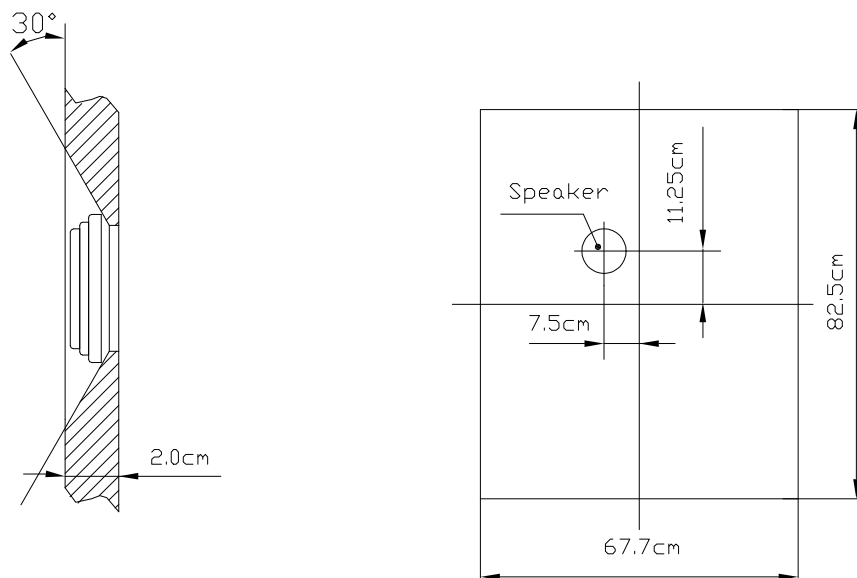

SPECIFICATION FOR APPROVAL
承认书

PAGE NO.
页码

8/9

PART . NO.
产品型号

MID2899-004-02

FREQUENCY RESPONSE (fig.3)

曲線圖

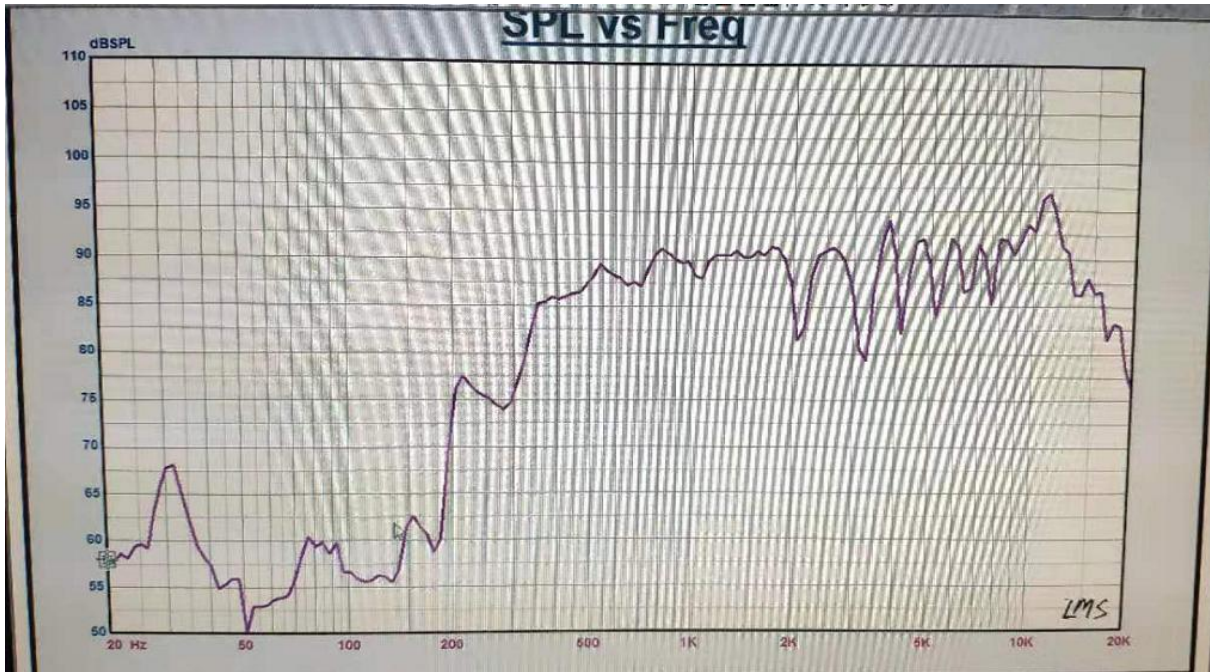

7

DROP TEST (fig.4)

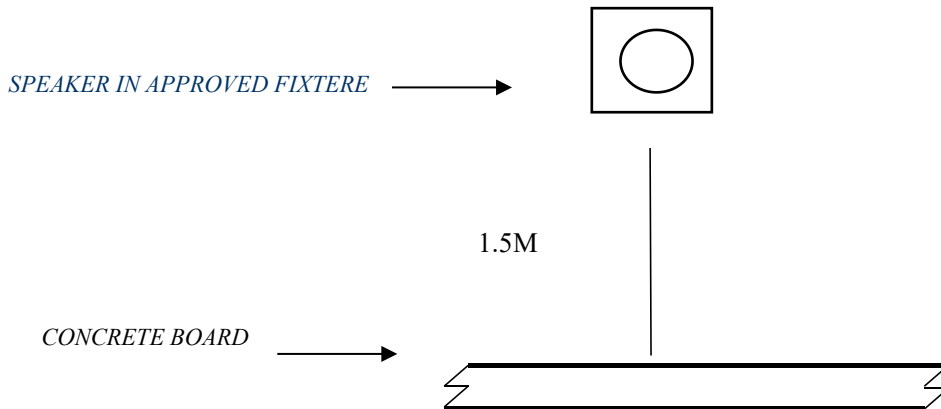

8

Fig4. Outer dimension

SPECIFICATION FOR APPROVAL
承认书

PAGE NO.
页码

9/9

PART . NO.
产品型号

MID2899-004-02

9. 包装图 PACKING

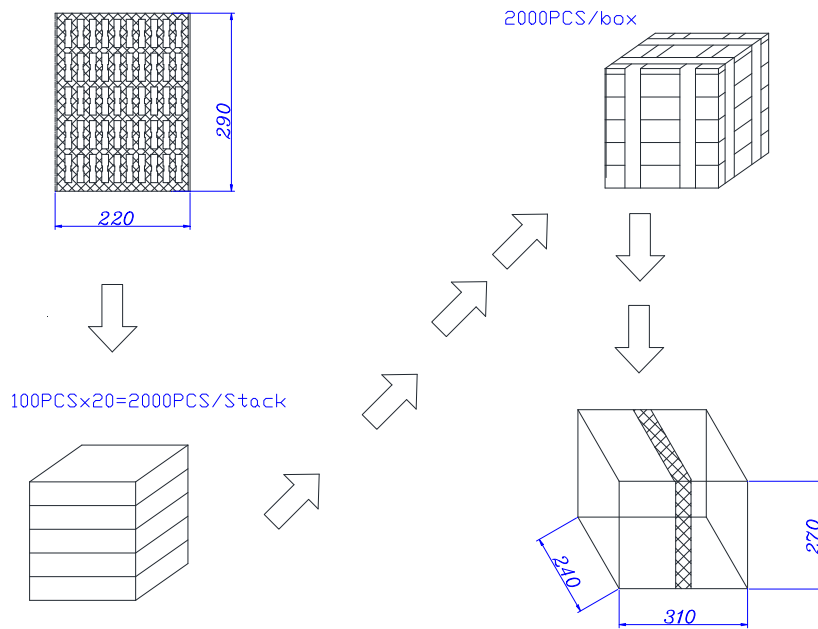

每盘 100 个 100pcs of speaker in each tray
每箱 20 盘 20 trays in one carton
总计:2000 个 / 1 箱 Total:2000 pcs / 1 carton
毛重: 4.0KGS Gross Weight:4.0KGS
净重: 2.5KGS Net Weight: 2.5KGS

Fig5. Packing dimension