

SPECIFICATION FOR APPROVAL

承认书

Customer (客户) : _____

Product Name (产品名称) : 微型扬声器

Zhenmei Part No. (臻美型号): MIML36A008001-01

Specification (臻美规格) : 8 Ω 1W

Customer' s Model No. (客户型号): _____

Specification No. (规格书编号): MI-PS-36A008001-01

Number of the edition (版本号) : A0

CUSTOMER' S APPROVED SIGNATURE 客户承认盖章		



广东臻美智能电子科技有限公司

Guangdong zhenmei intelligent electronic technology co., ltd.

地址:广东省东莞市塘厦镇华新智慧工业园华新路 22 号

TEL: 400-659-1989 FAX:0769-82196690

Http: www.zhenmeigd.com

E-MAIL: sales888@zhenmeigd.com

Approved by 核准	Checked by 审核	Issued by 制成

SPECIFICATION FOR APPROVAL 承认书	PAGE NO. 页码	2/7
	PART . NO. 产品型号	MIML36A008001-01

1. 简介 SCOPE

本产品适用于电脑、手机、对讲机等人工智能安防系统等产品

This product is suitable for computer, mobile phone, walkie talkie and other artificial intelligence security system products

2. 外观尺寸图 MECHANICAL LAYOUT & DIMENSIONS

见图 Shown in Fig.4

3. 概要 GENERAL REQUIREMENTS

3.1 使用温度 OPERATING TEMPERATURE RANGE: $-20^{\circ}\text{C} \sim +60^{\circ}\text{C}$

3.2 储存温度 Storage Temperature: $-30^{\circ}\text{C} \sim +70^{\circ}\text{C}$

3.3 标准测试条件 STANDARD TEST CONDITIONS:

温度 Temperature: $17\sim 25^{\circ}\text{C}$ 湿度 Relative Humidity: $45\sim 80\%(\text{RH})$

大气压力 Air Pressure: $860\sim 1060 \text{ MPa}$

3.4 仲裁测试条件 JUDGEMENT CONDITIONS:

温度 Temperature: $20\pm 2^{\circ}\text{C}$ 湿度 Relative Humidity: $60\sim 70\%(\text{RH})$

大气压力 Air Pressure: $860\sim 1060 \text{ MPa}$

4. 扬声器规格 SPEAK ELECTRICAL AND ACOUSTICAL SPECIFICATION

4.1 声压级 Sound Press Level (SPL): $91\pm 3 \text{ dB SPL} / 2.83\text{V}/10\text{CM}$ at 2000Hz, in 1cc box

4.2 阻抗 IMPEDANCE: $8\pm 15\% \Omega$

4.3 频响曲线 FREQUENCY RESPONSE CURVE: As shown in fig(2)

4.4 谐振频率 RESONANCE FREQUENCY: $520\pm 20\text{Hz}$ in free air

4.5 额定功率 Rated Power: 1W in 1CC box

4.6 最大功率 Max. Power: 1.5W must be normal white noise for 1 minute in 1.0cc box

4.7 谐波失真 DISTORTION : $10\% \text{ Max. } 2\text{kHz}$ (Mounted in 1cc measure box and in a baffle) Test at $2.83\text{Vrms}/10\text{cm}$

4.8 纯音 AUDIBLE NOISE: Must be free audible noise 300Hz-10KHz; 2.83Vrms , while testing in 1cc box.

4.9 极性 POLARITY: Right side is the "+", As show in the picture

4.10 重量 Weight: Approx. 5g

SPECIFICATION FOR APPROVAL
承认书

PAGE NO.
页码

3/7

PART . NO.
产品型号

MIML36A008001-01

■测试方法图 MEASURING CIRCUIT (Fig. 1)

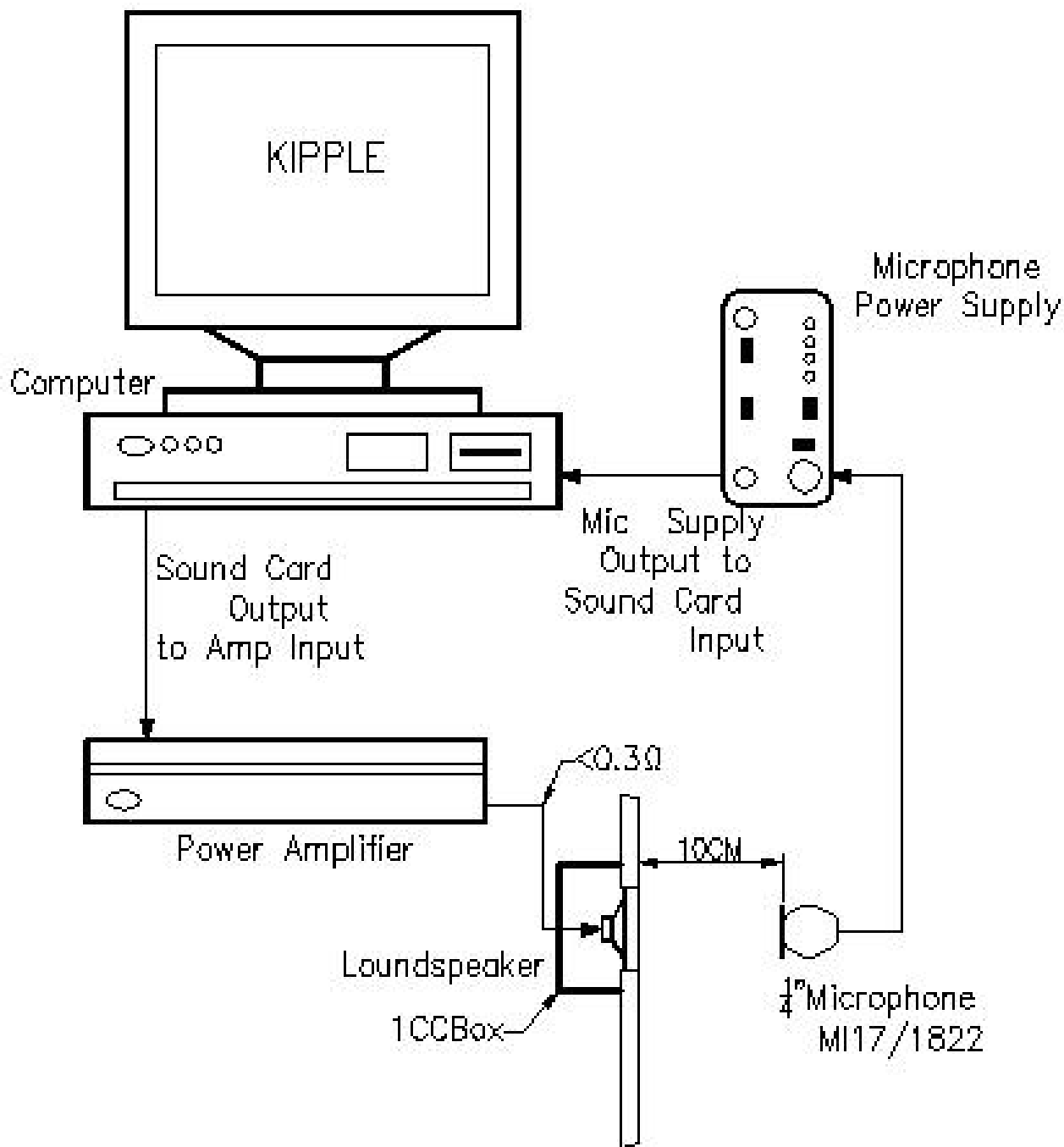

Fig.1 measuring diagram

SPECIFICATION FOR APPROVAL
承认书

PAGE NO.
页码

4/7

PART . NO.
产品型号

MIML36A008001-01

■ 频率响应曲线图 TYPICAL FREQUENCY RESPONSE CURVE (Fig. 2)

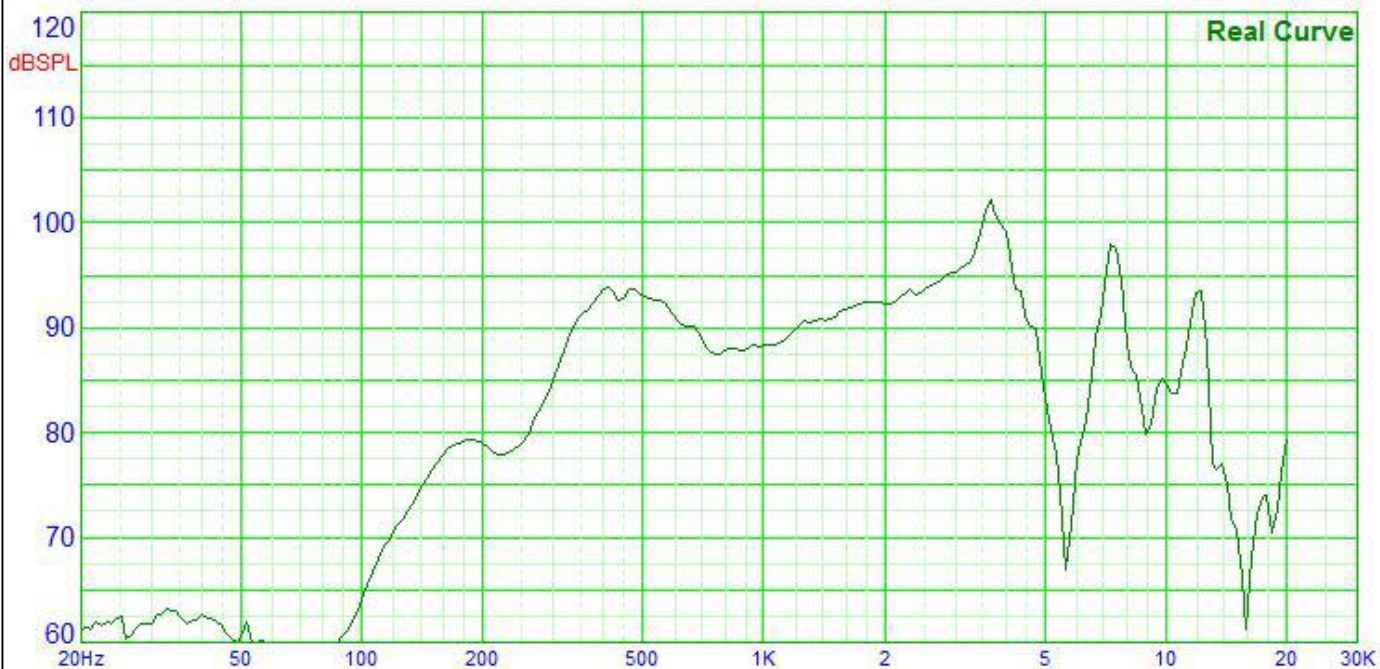
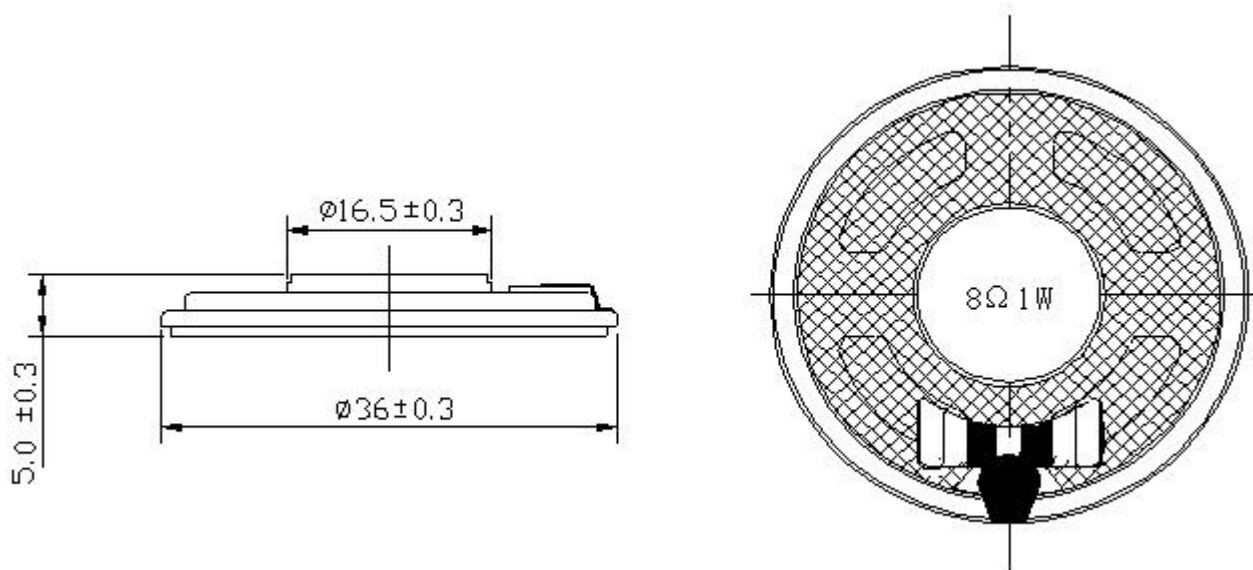

Fig.2 Typical frequency response curve

■ 外观尺寸图 DIMENSIONS (Fig. 3)



SPECIFICATION FOR APPROVAL
承认书

PAGE NO.
页码

5/7

PART . NO.
产品型号

MIML36A008001-01

5. 可靠性测试 RELIABILITY TESTS

扬声器进行下列测试后 SPL 变化不允许超出±5dB，不允许有任何机械或者热损伤。

The sound pressure as specified shall neither deviate more than ±5dB from the initial value, nor any significant damage after any of following testing.

5.1 高温试验 HIGH TEMPERATURE TEST

High temperature: **+70±2℃**

Duration: **16 hours**

5.2 低温试验 LOW TEMPERATURE TEST

Low temperature : **-30±2℃**

Duration: **16 hours**

5.3 冷热冲击试验 HEAT SHOCK TEST

High temperature: **+70±2℃**

Low temperature: **-30±2℃**

Changeover time: **< 30 seconds**

Duration: **1 hour**

Cycle: **5**

5.4 高温高湿试验 HUMIDITY TEST

Temperature: **+40±2℃**

Relative humidity: **90~95%**

Duration: **16 hours**

5.5 高低温循环试验 TEMPERATURE CYCLE TEST

Temperature: **-30℃ +20℃ +70℃**

Duration: **30 minutes 15 minutes 30 minutes**

Temperature gradient: **1~3℃/min.**

Cycle: **5**

5.6 跌落试验 DROP TEST

Free drop a unit to the surface of 10mm thick board

Height: **100cm**

Cycle: **6 (1 each plain) onto the concrete board**

5.7 可靠性试验 Load test

White Noise.: **20~20kHz** Rated Power: **1W** **96Hours in lcc box**

SPECIFICATION FOR APPROVAL 承认书	PAGE NO. 页码	6/7
	PART . NO. 产品型号	MIML36A008001-01

编号 No.	零件名称 PART NAME	材料 MATERIAL	数量 Q' TY	备注 REMARK
1	主架 FRAME	PPA or PBT	1	
2	磁钢 MAGNET	NdFeB	1	
3	极片 POLE PIECE	SPCC	1	
4	U 铁 U YOKE	SPCE	1	
5	膜片 DIAPHRAGM	PEEK or PEN	1	
6	音圈 VOICE COIL	COPPER WIRE	1	
7	前盖 FRONT CAP	PPA or PBT	1	
8	焊片 SPRING TERMINAL	SUS	2	
9	垫圈 GASKET	0.3T	1	

Fig4. Outer dimension

SPECIFICATION FOR APPROVAL
承认书

PAGE NO.
页码

7/7

PART . NO.
产品型号

MIML36A008001-01

7. 包装图 PACKING (仅供参考)

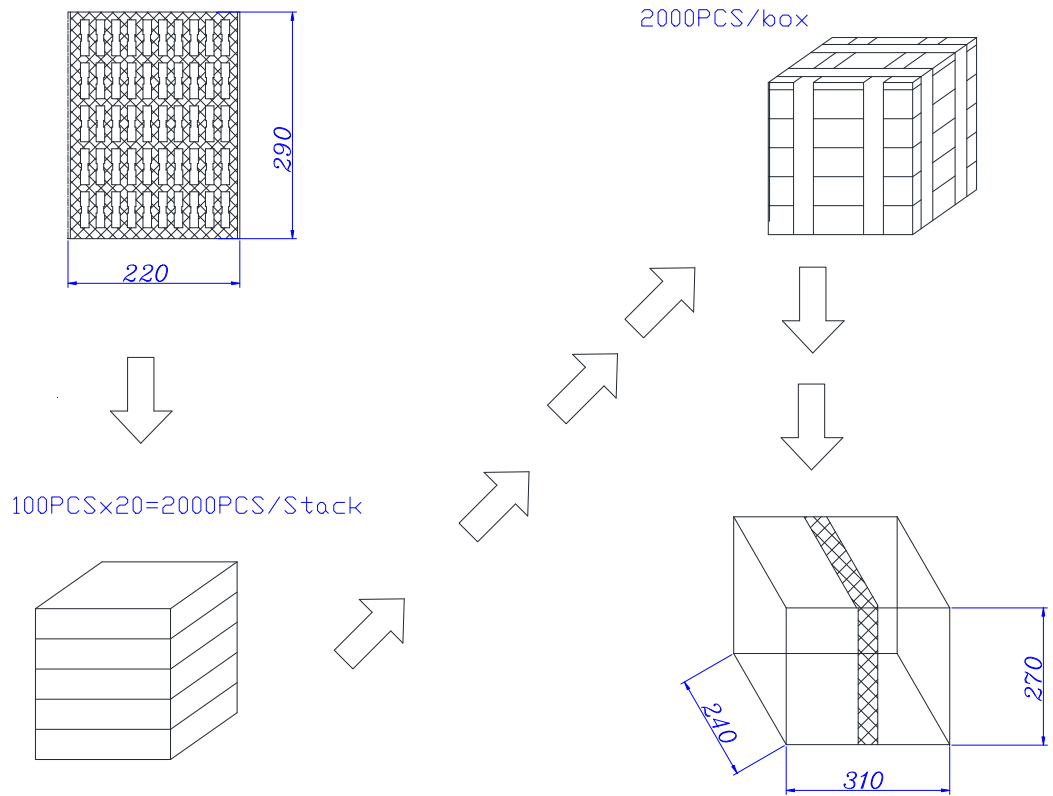

每盘 100 个	100pcs of speaker in each tray
每箱 20 盘	20 trays in one carton
总计:2000 个 / 1 箱	Total:2000 pcs / 1 carton
毛重: 4.0KGS	Gross Weight:4.0KGS
净重: 2.5KGS	Net Weight: 2.5KGS

Fig5. Packing dimension